

General Specifications

EXA PH

Model PH100
EXA100 Series
Panel Mount pH Measurement System

GS 12B11A01-01E

GENERAL

The EXA100 series is based on the compact, simple and reliable panel-mount PH100 pH converter, which provides necessary basic functionality, and is targeted at cost-sensitive unattended applications. Self-diagnostic functions minimize the cost of ownership.

A line of miniature, lightweight EXA100 series sensors is available, and other Yokogawa pH sensors (such as the PH8EFP and PH8ERP) or other companies' sensors may be used.

Matching EXA100 series adapter, immersion or guide-pipe holders are available.

Yokogawa is a leader in process automation and pH measurement systems, and the Yokogawa brand delivers reliability that you can depend upon.

FEATURES

- 96 x 96 mm panel mount design for indoor use
- Easy access to routine maintenance mode
- Practical functions packed in a compact housing
- Large 4-digit display
- One analog output and two/four contact outputs as standard
- Simple one touch automatic calibration
- Self-diagnostics (e.g., calibration failure, measuring range failure, converter failure)



Converter



Sensors



Guide-pipe Holder



Immersion Holder

SYSTEM CONFIGURATION

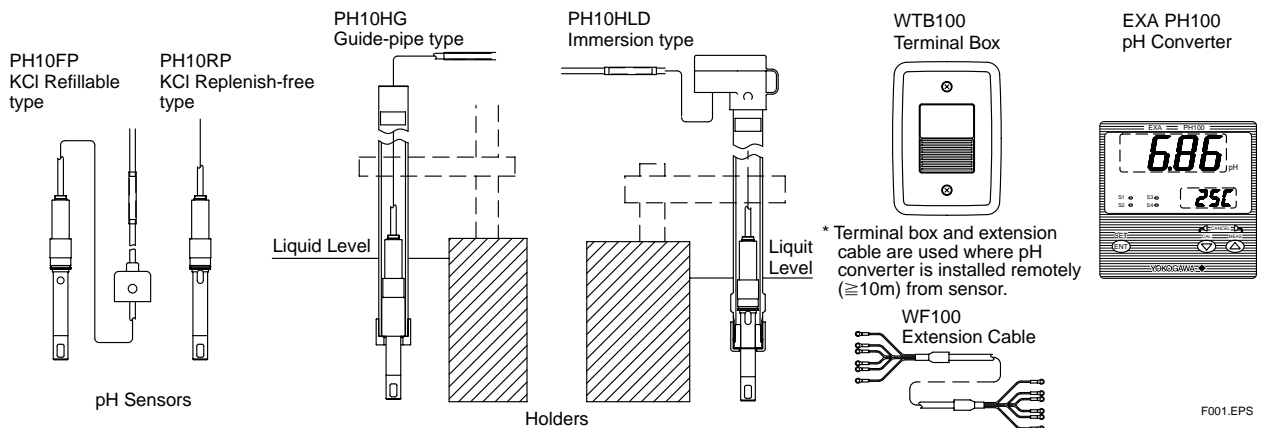

■ GENERAL SPECIFICATIONS

1. Panel Mounted pH Converter

Model : PH100

Measurement : Hydrogen ion concentration (pH) of a solution

Measuring range : 0.00 to 14.00 pH Indication

Display : Digital (LED)

Range : -2.00 to 16.00 pH

Resolution : 0.01 pH (pH reading), 1 °C (temperature reading)

Indication items : pH reading, setting, status, temperature *1

*1: Indication "enabled/disabled" selectable

Input signal

pH input range : -2 to 16 pH

Temperature input *2 : Pt1000/Pt100, Pt1000/500 Ω, Pt1000/10 kΩ, Pt1000/6.8 kΩ

*2 : Must be specified when ordering.

Temperature input range : -10 to 110 °C

Transmission signal output

Number of output points : 1 output, pH reading only

Output signal : 4-20 mA DC, isolated

Load resistance : 600Ω or less

Transmission signal range : Configurable within measuring range

Minimum span : 2 pH

Maintenance output signal : Output hold "enabled/disabled" selectable

Hold output value : Last measured value/preset value (2.0 to 20.8 mA) selectable

Fail output signal : Downscale burnout (2 mA) "enabled/disabled" selectable

Contact output

Contact type : Relay contact output

Number of contacts : 2 or 4 outputs (must be specified when ordering)

Contact action : On/Off action

Contact functions : Selectable: High, low, high-high, low-low, high-high/low-low limit alarms, FAIL

Contact output hysteresis : 0.0 to 4.0 pH (configurable)

Contact output delay time : 0 to 200 seconds (configurable)

Contact rating :

When 2 contact outputs specified

S1 : 240 VAC 3A or 30 V DC 3A (resistance load), Form C (NC/NO/COM, 3 terminals)

S2 : 240 VAC 3A or 30 V DC 3A (resistance load), Form A

When 4 contact outputs specified

S1 : 240 VAC 3A or 30 V DC 3A (resistance load), Form C (NC/NO/COM, 3 terminals)

S2, S3, S4 : 240 V AC 3A or 30 V DC 3A

(resistance load), Form A, shared common

Maximum load current on common is 3A.

Contact status:

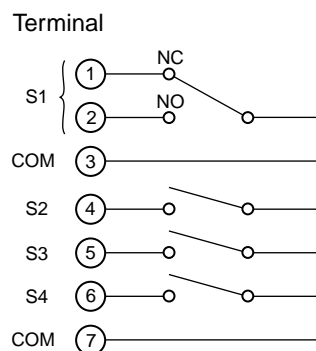

F011E.eps

Contact		Function selected					
		H, L, HH, LL, HH/LL limit alarms			FAIL		
		Power off	Power on		Power off	Power on	
		No alarm	Alarm		No alarm	Alarm	
S1	NO-COM	Open	Open	Closed	Open	Closed	Open
	NC-COM	Closed	Closed	Open	Closed	Open	Closed
S2		Open	Open	Closed	Open	Closed	Open
S3 when specified		Open	Open	Closed	Open	Closed	Open
S4 when specified		Open	Open	Closed	Open	Closed	Open

Note: When a contact is activated, the LED on display panel turns on.

T01E.EPS

Ambient temperature : -5 to 45 °C

Storage temperature : -25 to 70 °C

Ambient humidity : 10 to 90% RH, non-condensing

Construction : Front panel : Dust-proof and drip-proof construction IP55

IP65 (when "/65" option specified)

Materials : ABS resin and polycarbonate

Power supply : Rated voltage 100 to 240 V AC (±10%), 50/60 Hz

Power consumption : Max. 9 VA

Weight : Approx. 600g

Dimensions : 96 (W) x 96 (H) x 129 (D) mm

Mounting : Panel mount

Panel cutout dimensions : 92 (W) x 92 (H) mm

Wiring : M4 screw terminal (Protective ground terminal), M3.5 screw terminal (other terminals)

Grounding : Ground to earth (grounding resistance 100Ω or less)

Functional specifications

Asymmetry potential adjustment range : 7 ± 2 pH
 Slope adjustment range : 70 to 110% of theoretical value
 Automatic temperature compensation range : -10 to

110 °C, manual temperature compensation available (setting range : -10 to 110 °C)

Temperature correction function (cable length correction by one-point temperature calibration)

Calibration function

One touch automatic calibration (one or two point calibration)

Standard solution table : Selectable : JIS•NIST Table (4, 7, 9 pH)

DIN 19267 Table (4, 7, 9 pH)

US Technical Buffer Table (4, 7, 10 pH)

Standard solution temperature range : 0 to 95 °C for JIS•NIST Table

0 to 90 °C for DIN 19267 Table

0 to 60 °C for US Technical Buffer Table

Manual calibration (one or two point calibration at specified setpoint(s))

Self-diagnostics function

FAIL output : pH measurement range failure, temperature measurement range failure, temperature detection element failure, and converter failure

Detection during calibration, error indication :

Standard solution temperature range failure, asymmetry potential failure, electromotive force slope failure, stability failure

Converter performance : under normal operating conditions

Linearity : ± 0.03 pH

Repeatability : ± 0.02 pH

Transmission output accuracy : $\pm 0.3\%$ of span

Sensors connectable with PH100 : PH10FP, PH10RP, PH8EFP, PH8ERP

FU20 (no ORP measurement available)

Sensors conditionally connectable : PH8ERG, PH8EFG, other companies' sensors (no temperature compensation available, manual temperature compensation required)

Maximum total connection cable length : 50 m (sensor cable length included)

2. pH Sensors for PH100

Model : PH10□P

Measurement : Hydrogen ion concentration (pH) of a solution

Measurement principle : Glass electrode method

Model : PH10FP (KCl Refillable type) or PH10RP (KCl Replenish-free type)

Measuring range : 0 to 14 pH (PH10FP)
 2 to 12 pH (PH10RP)

Installation : PH10RP/ADP piping adapter connection (PH10RP)

Incorporated in PH10HG Guide-pipe Holder (PH10RP)

Incorporated in PH10HLD Immersion Holder (PH10RP/PH10FP)

Sample temperature range : 0 to 60 °C (PH10RP)
 0 to 70 °C (PH10FP)

Sample pressure : Atmospheric pressure (depth: 3 m max.)

Sample flow rate : 2 m/s max.

Sample conductivity : 50 μ S/cm or greater

Temperature detection element : Pt1000

Wetted part materials : Polypropylene, rigid PVC resin, silicone rubber, glass, ceramics, chlorinated polyethylene rubber (cable sheath), fluorinated rubber (adapter O-ring for piping connection)

Adapter (optional) material : Rigid PVC resin

Cable length : 3, 5, 10 m (up to 50 m with sensor cable included when using terminal box)

Weight Approx. : 300g (3 m), 450g (5 m), 800g (10 m)

3. Holders (Immersion/Guide-pipe Type) for PH100

Model : PH10HLD Immersion Holder

Weight : Approx. 400g (1 m), 800g (2 m)

Holder length : 1 or 2 m

Materials : Polypropylene (holder), polyethylene (spacer), silicone rubber (gasket), ethylene propylene rubber (cover)

Operating temperature : 0 to 70 °C

Operating flow rate : 2 m/s or less

Model : PH10HG Guide-pipe Holder

Weight : Approx. 450g (1 m), 850g (2 m), 1.3kg (3 m), 1.7kg (4 m)

Holder length : 1, 2, 3, or 4 m

Materials : Rigid PVC resin

Operating temperature : 0 to 60 °C

Operating flow rate : 2 m/s or less

4. Terminal Box for PH100

Model EXA WTB100 :

Construction : Outdoor installation, JIS C0920 rain-proof

Case material : Glass fiber filled polycarbonate resin

Case color : Grayish green (Munsell 2.5G5.0/1.0 equivalent)

Mounting : Bracket mounting (no hardware required), pipe mounting (optional hardware), wall mounting (optional hardware)

Weight :

Body : Approx. 0.5kg

Mounting hardware (optional) : Approx. 0.7kg (pipe mounting), 0.3kg (wall mounting)

Operating ambient temperature : -10 to 50 °C

Cable inlet : (to be drilled for wiring)

For sensor cable : 13 mm diameter hole, JIS A8 equivalent cable gland included

For dedicated extension cable : 21 mm diameter hole, JIS A15-equivalent cable gland included

Note : WF100 extension cable (but not sensor cable) can be protected by conduit using conduit adapter. A conduit adapter is supplied when "AWTB" or "ANSI" option code is specified.

5. Dedicated Cable for Terminal Box for EXA100

Model WF100 :

Type : Specialty 4-conductor cable

Finished outside diameter : 6.5 mm

Sheath material : Chlorinated polyethylene rubber

■ Model and Suffix Codes

1. PH100 Panel Mounted pH Converter

Model	Suffix code	Option code	Description
PH100	-----	-----	Panel mounted pH converter
-----	-A	-----	Always -A
Label language	-E	-----	English
	-J	-----	Japanese
Contact output	-21	-----	2 contact outputs
	-41	-----	4 contact outputs
Temperature sensor	-T1	-----	Pt1000/Pt100
	-T2	-----	Pt1000/500 Ω
	-T3	-----	Pt1000/10 kΩ
	-T4	-----	Pt1000/6.8 kΩ
-----	-NN	-----	Always -NN
Option	Construction	/65	with sealing

T02E.EPS

Maintenance Parts

Parts Name	Parts No.	Description
Mounting bracket	T9115NL	Large bracket (mount at up) and small bracket (mount at bottom)

2. pH Sensors for PH100

PH10FP KCl Refillable pH Sensor

Model	Suffix code	Option code	Description
PH10FP *1	-----	-----	KCl Refillable pH sensor for PH100
Cable length	-03	-----	3m
	-05	-----	5m
	-10	-----	10m
-----	-AA	-----	Always -AA
Combination holder	-HST	-----	For KCl-filled immersion type holder *2
-----	-NN	-----	Always -NN

Notes *1 : Sensor cannot be used as a single unit and requires a dedicated immersion type holder, PH10HLD-AA-□□-HST-PE, which should be ordered separately.

*2 : Sensor cable incorporates the cover for a holder.

*3 : KCl solutions for refill should be prepared by customer (ref. P/N K9084LP: KCl solution in six 250 ml-polyethylene bottles)

T03E.EPS

PH10RP KCl Replenish-free pH Sensor

Model	Suffix code	Option code	Description	
PH10RP	-----	-----	KCl Replenish-free pH sensor for PH100	
Cable length	-03	-----	3m	
	-05	-----	5m	
	-10	-----	10m	
-----	-AA	-----	Always -AA	
Combination holder	Adapter	-ADP	-----	For piping adapter *1
	Immersion type	-HSS	-----	For immersion type holder *3
	Guide-pipe type	-GDH	-----	For guide-pipe type holder *2
-----	-NN	-----	Always -NN	
Option	Piping adapter	/ADP	Piping adapter for replenish-free type sensor R3/4	

Notes *1 : O-ring for piping adapter (/ADP) is included. Must be selected when optional piping adapter is specified.

*2 : Configuration is PH10HG guide-pipe holder.

*3 : PH10HLD Immersion holder should be ordered separately.

T04E.EPS

3. Holders for PH100

PH10HLD Immersion Holder for PH10□P

Model	Suffix code	Option code	Description
PH10HLD	-----	-----	Immersion holder for PH10□P/OR10□P *1
-----	-AA	-----	Always -AA
Holder length	-10	-----	1m
	-20	-----	2m
Combination sensor	-HST	-----	For PH10FP KCl Refillable sensor *2
	-HSS	-----	For PH10RP KCl Replenish-free sensor
-----	-PE	-----	Always -PE
Option	KCl powder	/KCL	KCl powder *3
	Mounting hardware	/MS1	Mounting hardware, 1 set
		/MS2	Mounting hardware, 2 sets
		/CALK	Calibration holder fixing hardware

Notes *1 : Applicable sensors are PH10□P and OR10□P, which should be ordered separately.

*2 : KCl Refillable sensors (PH10FP/OR10FP) require KCl-filled immersion type holders.
KCl pressurized type is not available.

KCl solution is not filled in the holder upon shipment. Holders can be filled with KCl solution : 500 mL for 1-m holder and 1000 mL for 2-m holder, which can be prepared by selecting the option.

During measurement, KCl solution level should be higher than sample solution level.

*3 : KCl powder is packed in 8 bags, each for 250-ml solution. (ref. 2 bags used for 1-m holder and 4 bags for 2-m holder)
KCl solutions can be purchased as an auxiliary part.

(ref. P/N K9084LP: KCl solution in six 250 ml-polyethylene bottles)

T05E.EPS

PH10HG Guide-pipe Holder for PH10RP/OR10RP

Model	Suffix code	Option code	Description
PH10HG	-----	-----	Guide-pipe holder for PH10RP/OR10RP *1
-----	-AA	-----	Always -AA
Holder length	-10	-----	1m
	-20	-----	2m
	-30	-----	3m
	-40	-----	4m
Material	-PVC	-----	PVC
-----	-NN	-----	Always -NN
Option	Mounting hardware	/MS1	Mounting hardware: 1 set
		/MS2	Mounting hardware: 2 sets

Notes *1 : Applicable sensors are PH10RP and OR10RP KCl Replenish-free sensors only.

T06E.EPS

4. WTB100 Terminal Box for EXA100

Model	Suffix code	Option code	Description
WTB100	-----	-----	Terminal box for EXA100 Series
Measurement system	-PH	-----	For PH100
	-OR	-----	For OR100
	-SC	-----	For SC100
	-NN	-----	Always -NN
Option	Mounting hardware	/P	For pipe mounting
		/W	For wall mounting
	Conduit adapter	/AWTB	Conduit connection: G1/2 female
		/ANSI	Conduit connection: 1/2 NPT

T07E.EPS

Note: Conduit adapter will protect the extension cable with a conduit from damage. Attach conduit adapter to the cable gland of the extension cable and the extension cable opening on the terminal box. Conduit use is prohibited to sensor cable.

5. WF100 Cable for Terminal Box for EXA100

Model	Suffix code	Option code	Description
WF100	-----	-----	Extension cable for EXA100 Series
Measurement system	-PH	-----	For PH100
	-OR	-----	For OR100
	-SC	-----	For SC100
Option	Cable length	/C01	5m
		/C02	10m
		/C03	15m
		/C04	20m
		/C05	25m
		/C06	30m
		/C07	35m
		/C08	40m
		/C09	45m

Note *1 : Total length including sensor cable length should not exceed 50 m.

T08E.EPS

■ External Wiring Diagram

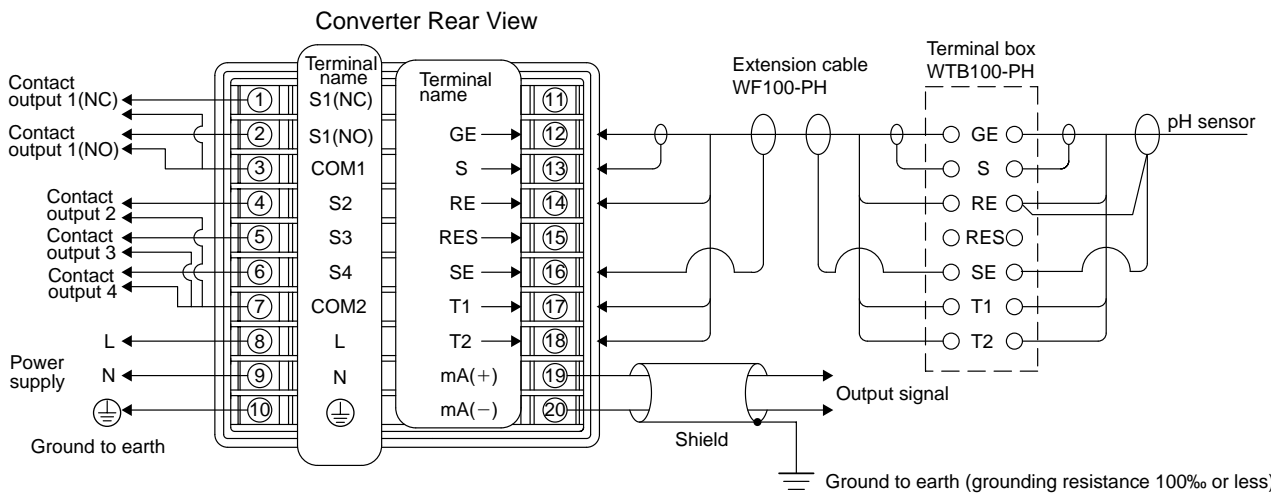

F002E.EPS

■ Dimensions

1. PH100 Panel Mounted pH Converter

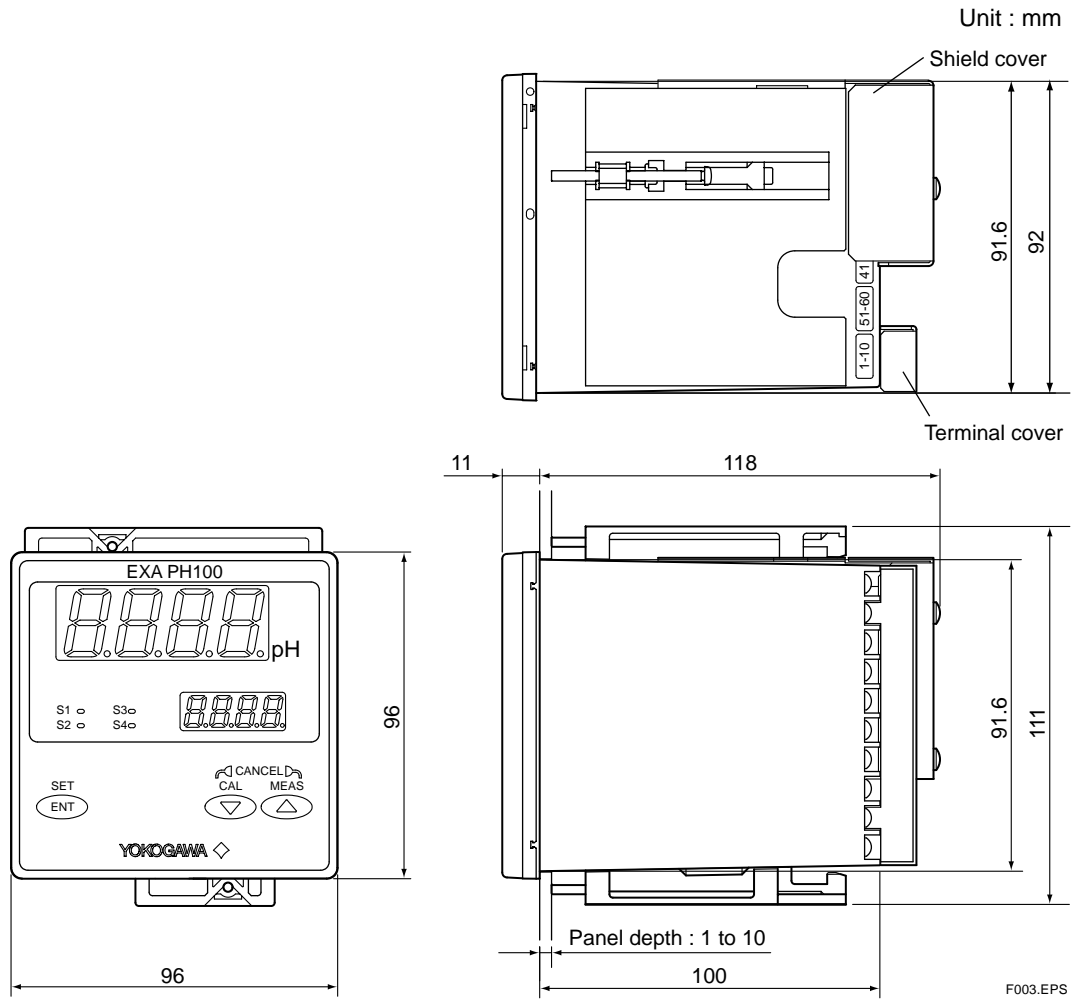

Panel Cutout Dimensions

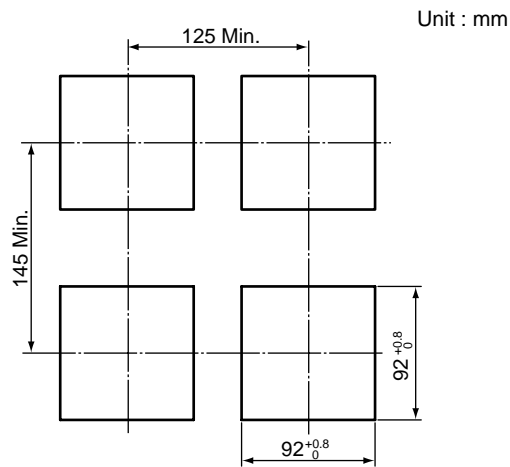

2. PH10FP and PH10RP pH Sensors for PH100

<PH10FP KCI Refillable pH Sensor >

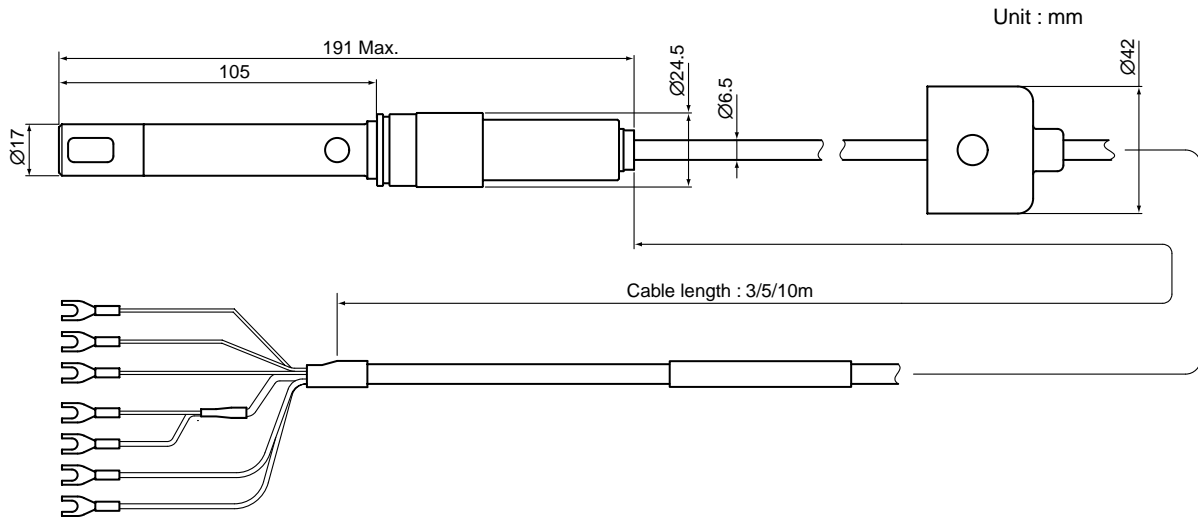

<PH10RP KCI Replenish-free pH Sensor>

• PH10RP-□□-AA-GDH-NN

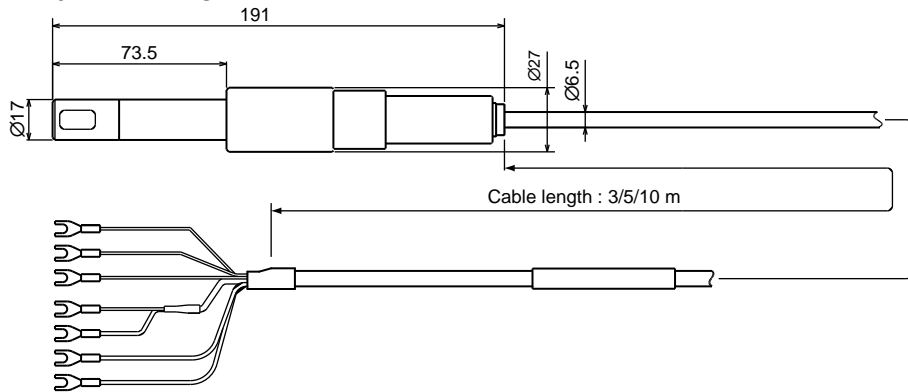

• PH10RP-□□-AA-ADP-NN/ADP

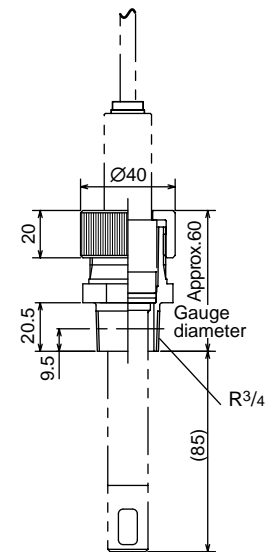

• PH10RP-□□-AA-ADP-NN

• PH10RP-□□-AA-HSS-NN

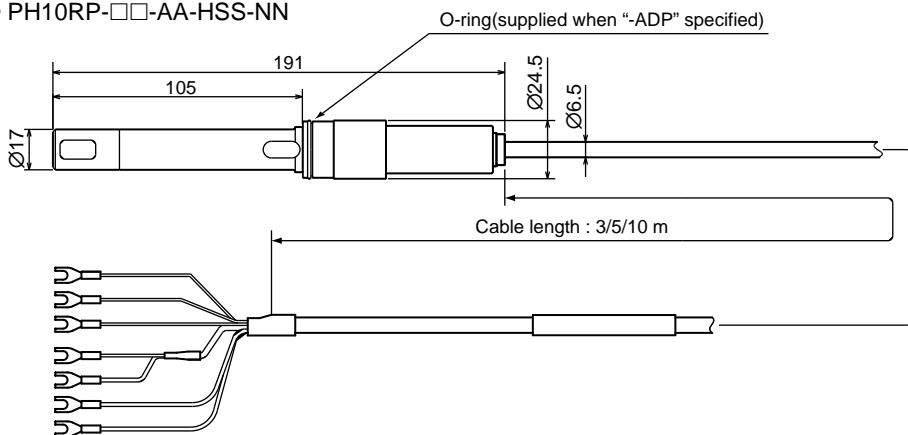

<Optional Adapter>

• /ADP

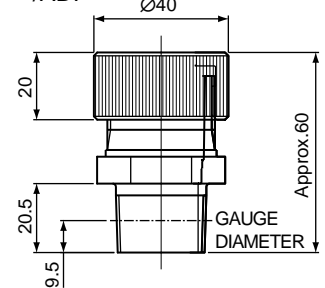

3. PH10HLD Immersion Holder, and PH10HG Guide-pipe Holder

<PH10HLD>

Unit : mm

- PH10HLD-AA-□□-HST-PE

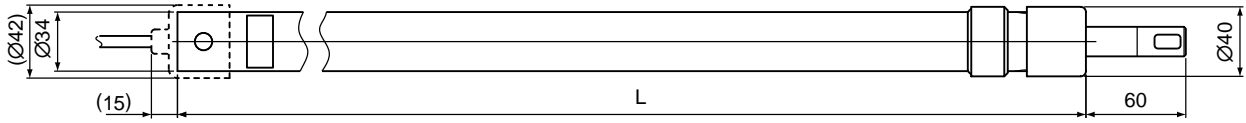

- PH10HLD-AA-□□-HSS-PE

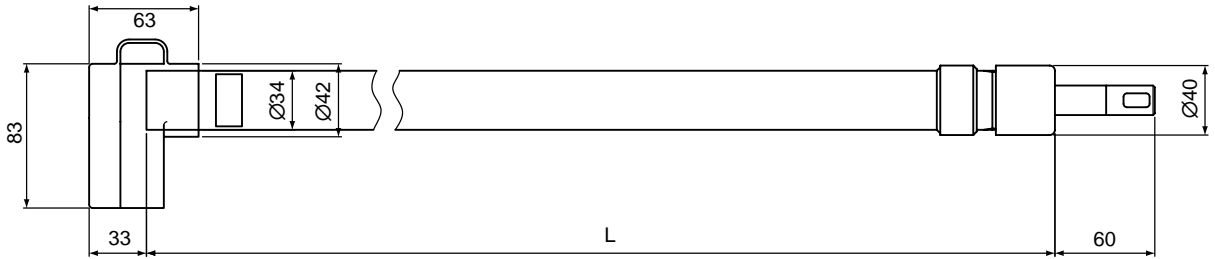

MS Code	L(Holder length)
PH10HLD-AA-10-□□□-PE	1000mm
PH10HLD-AA-20-□□□-PE	2000mm

<PH10HG>

- PH10HG-AA-□□-PVC-NN

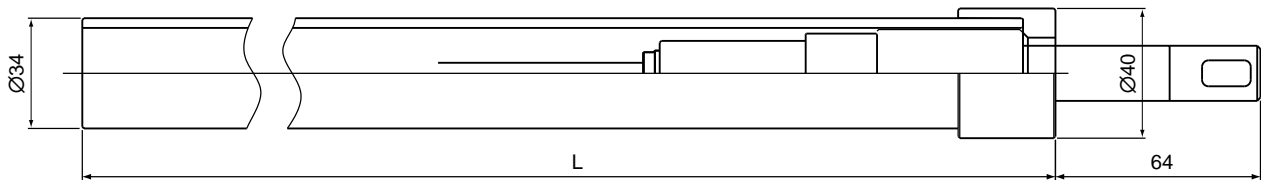

MS Code	L(Holder length)
PH10HG-AA-10-PVC-NN	1000mm
PH10HG-AA-20-PVC-NN	2000mm
PH10HG-AA-30-PVC-NN	3000mm
PH10HG-AA-40-PVC-NN	4000mm

CAUTION



Installation Location of Holders (Guide Pipe, Submersion Type, etc)
 The holder should be used in a place that is as vibration free as possible.
 Using the holder in a place where it is affected by vibration, may result in damage to the holder.

• Mounting Hardware for Holders for PH100

/MS1: 1 set

/MS2: 2 sets

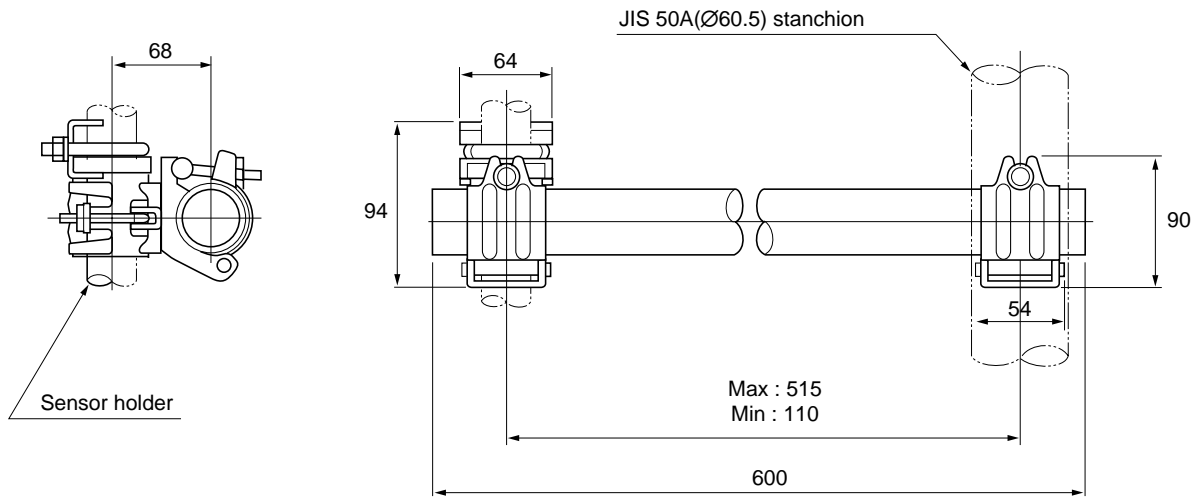

F012.EPS

• Calibration Holder Fixing Hardware for Holders for PH100

/CALK

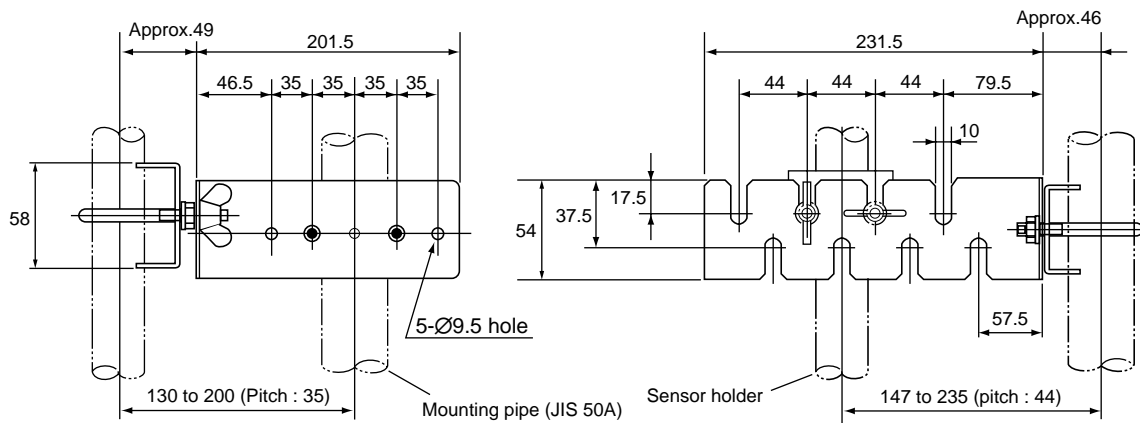

F013.eps

4. WTB100 Terminal Box

<WTB100-PH>

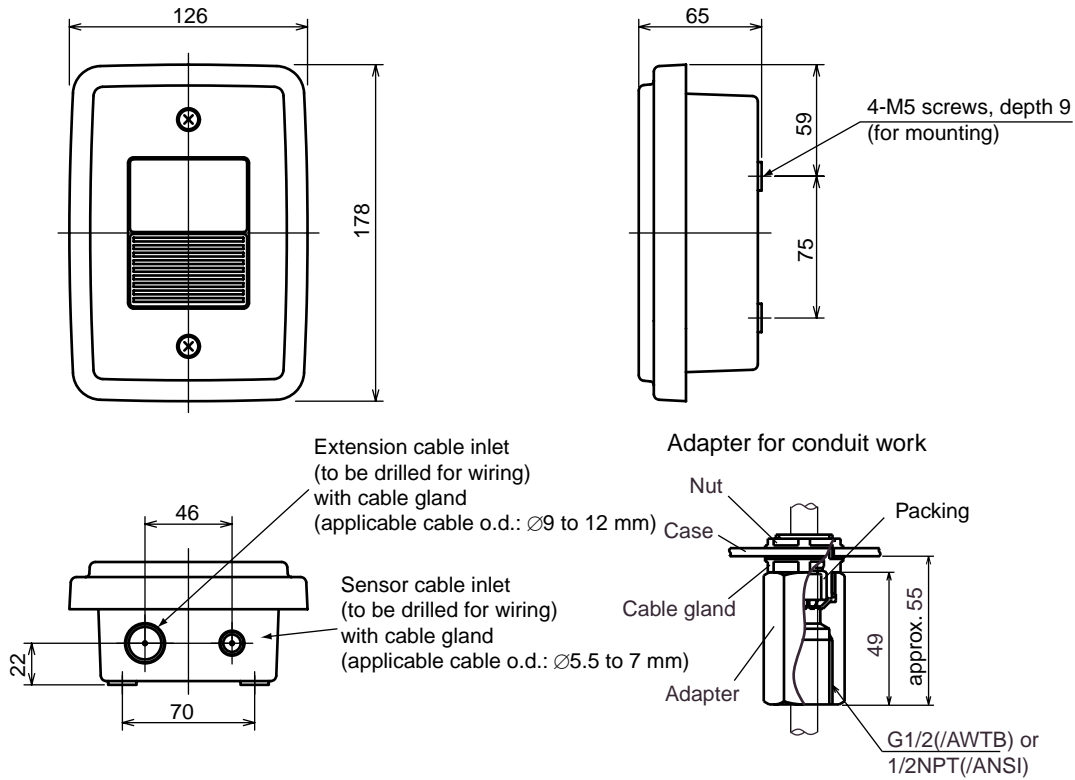

Note: Conduit adapter is used when the dedicated extension cable is protected by a conduit.
Attach it to the cable gland of the converter sensor cable inlet port and the cable gland of the terminal box extension cable.

Pip- mounting Bracket (Option code: /P)

Wall- mounting Bracket (Option code: /W)

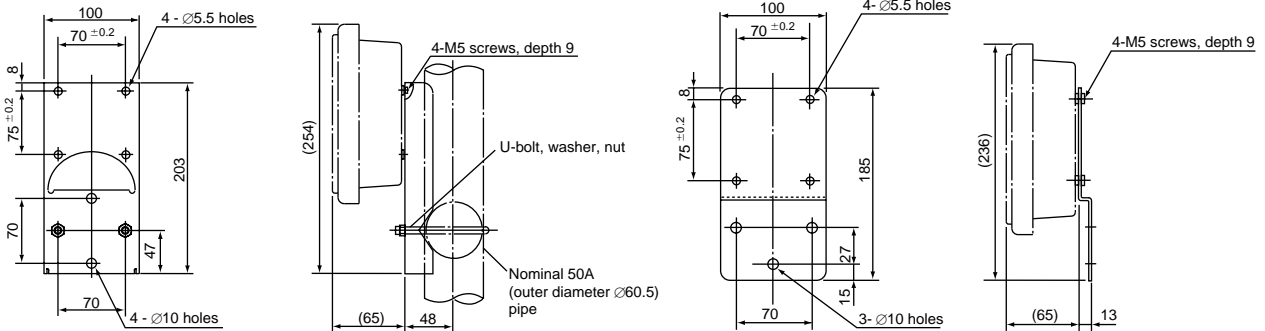

5. WF100 Extension Cable for Terminal Box

<WF100-PH>

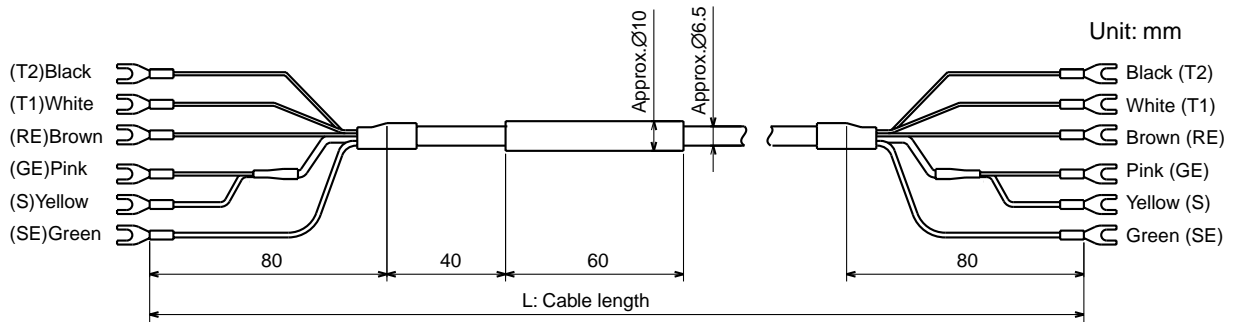

INQUIRY SHEET FOR PANEL MOUNT pH MEASUREMENT SYSTEM

Thank you for your interest in our panel mount pH measurement system. To make an inquiry, please check the appropriate box and fill in the blanks below.

General Information

Company name : _____
 Contact person : _____ Section : _____ Phone : _____
 Plant name : _____
 Equipment name : _____
 Measuring point : _____
 Purpose of measurement : Reading Recording Alarm Control
 Power supply : _____ VAC, _____ Hz

Measurement Conditions

(1) Sample name : _____
 (2) Sample composition : _____
 (3) Sample temperature : Max _____ Min _____ Normally _____ [°C]
 (4) Sample pressure : Max _____ Min _____ Normally _____ [kPa]
 (5) Flow rate : Max _____ Min _____ Normally _____ [L/min]
 (6) Velocity : Max _____ Min _____ Normally _____ [m/s]
 (7) Presence of slurry or contamination: No Yes
 1 Approx. _____ mg/l
 2 Approx. _____ mg/l
 3 Approx. _____ mg/l
 (8) SS concentration : Approx. _____ mg/l
 (9) Others : _____

Installation

(1) Ambient temperature : Approx. _____ °C
 (2) Installation site : Indoors Outdoors (Please consider another system)
 (3) Others : _____

Specification Requirements

(1) Measuring range : 0 to 14 pH _____
 (2) System configuration : Converter : PH100 Sensor : _____ Holder : _____
 Terminal box : _____ Extension cable : _____
 (3) Sensor cable length : 3 m 5 m 10 m _____ m
 (4) Sensor operating pressure : Atmospheric pressure
 Higher (PH10□P sensors are not applicable where the depth exceeds 3 m)
 (5) Holder type : Guide-pipe Immersion Piping adapter
 Others _____
 (6) Cleaning system : Not required
 Required (if so, please consider another system. EXA100 Series are not equipped with cleaning system.)
 (7) Others : _____