

UV Fluorescent Sulfur Dioxide Analyzer Model AF22M

Low level monitoring of
SO₂ from
1 ppb to 10 ppm



2M Series analyzer:

- Ultra compact and light – rack 3U
- SMD enhanced electronics
- High performance metrology
- Enhanced optical shutter
- Enhanced data logging functions
- ISO 10498 & EN 14212:2005 compliant

Reduced maintenance:

- Ease and accessibility of components
- Traceability of parts and consumables
- Remote maintenance and telediagnosics

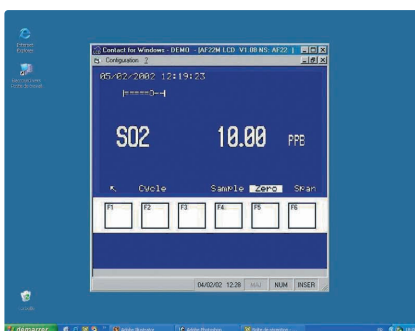

Remote Control

Major fields of applications:

- Ambient air monitoring
- Indoor air monitoring
- Mobile laboratory
- Air quality and stack monitoring of petrochemical, pulp & paper plants , water treatment plants
- Continuous emissions monitoring (CEM) by dilution extraction

Main features:

- Graphic Liquid Crystal Display (LCD)
- Interactive menu driven software with enhanced speed display
- Real-time synoptic flow diagram display
- User programmable ranges and average time
- Auto-ranging
- Temperature and pressure compensation
- Automatic and programmable response time
- Real time calibration graph
- Built-in storage of 2 months 1/4 h average data (up to 1 year with the optional memory extension)
- Built-in double serial interface (RS 232/RS 422) for remote control & maintenance

UV Fluorescent Sulfur Dioxide Analyzer - model AF22M

Specifications:

- Ranges: 0-0.1/0.2/0.5/1/2/5/10 ppm or user selectable ranges
- Autoranging between two-user specified ranges
- Noise (σ): 0.5 ppb
- Lower detectable limit (2σ): 1 ppb
- Response time: automatic and programmable (minimum 10 sec)
- Zero drift: less than 0.5 ppb / 24 h
less than 1 ppb / 7 days
- Span drift: less than 0.5 % / 24 h
less than 1 % / 7 days
- Linearity: $\pm 1\%$ of F.S.
- Pressure and temperature compensation
- Internal sample pump
- Sample flow rate: 0.3 lpm
- Averaging time: programmable from 1 min to 24h
- Data storage: 2 months quarterly average values
- Chassis: 19" rack mountable, 3U
- Dimensions (L x W x H): 545 mm x 483 mm x 133 mm
- Weight: 10 kg (22 lbs)
- Power: 115 V, 60 Hz - 230 V, 50 Hz
- Power consumption: 60 VA
- Operating temperature: 5 – 40 °C (typical as per US EPA 10 - 35° C)
- Digital output: 2 RS 232 or RS 422 ports
- PVDF sample filter holder
- Valves block for selection of customer – supplied zero and span gas

Options:

- ESTEL electronic board (1 or 2) with:
 - 4 independent analog inputs
 - 4 independent analog outputs
 - 4 remote control inputs
 - 6 dry contacts
- Built-in permeation bench with SO₂ tube and Filter – Valves block
- Memory extension (1 year of 1/4 h average values)
- 24V DC power supply for on-board applications
- Built-in H₂S \rightarrow SO₂ converter for H₂S low level monitoring
 - Ranges: 0-0.05/0.1/0.2/0.5/1 ppm or user selectable ranges
 - Cycle time: SO₂/H₂S: 7 min
 - SO₂ scrubber capacity: 500 ppm/ h
 - 3 selectable operating modes:
 - continuous H₂S
 - continuous SO₂
 - cyclic SO₂/H₂S
- Total Reduced Sulfur (TRS) external converter TRS \rightarrow SO₂ for TRS low level monitoring

Main Features:

The new model AF22M, sulfur dioxide analyzer, combines years of experience of a wide range of analyzers with an enhanced electronics package and a modular component parts design (measurement module, permeation module, 24V power supply module, analog input-output module, etc.).

The outcome is an ultra compact and light- rack 3U, easy-to-use analyzer capable of measuring sulfur dioxide at ppb levels. Applied to SO₂ measurement, the universally known UV fluorescent principle consists in detecting the characteristic fluorescence radiation emitted by SO₂ molecules. In the presence of a specific wavelength of UV light (214 nm) the SO₂ molecules reach a temporary excited electronic state. The subsequent relaxation produces a fluorescence radiation which is measured by a non-cooled photomultiplier tube (PM).

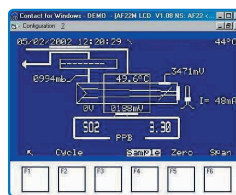

The analyzer was developed to meet customers' requirement for reduced and easier maintenance. Equipped with an enhanced aromatic hydrocarbon scrubbing system that guarantees complete removal of these interferents, the AF22M also achieves very high sensitivity and stability through the use of an optical shutter to compensate for PM drift.

The AF22M combines a powerful easy-to-use interface with quality components and design technology. Real-time calibration graphs can be displayed during span check operation. Multi-tasking software, combined with the LCD graphic display, gives a user-friendly access to the instrument set-up, as well as the status and maintenance parameters. Real-time synoptic, auto-diagnostic and maintenance data screens can be displayed while the instrument is operating. The new

electronics allow enhanced data storage of up to one year of 15 minutes averages, and total remote troubleshooting diagnostic capabilities via modem, using the analyzers complete display and functions emulation.

Equipped with the optional ESTEL I/O analog & digital board, the AF22M can be easily interfaced with other equipment and can be operated as a stand alone unit able to store several months of data.

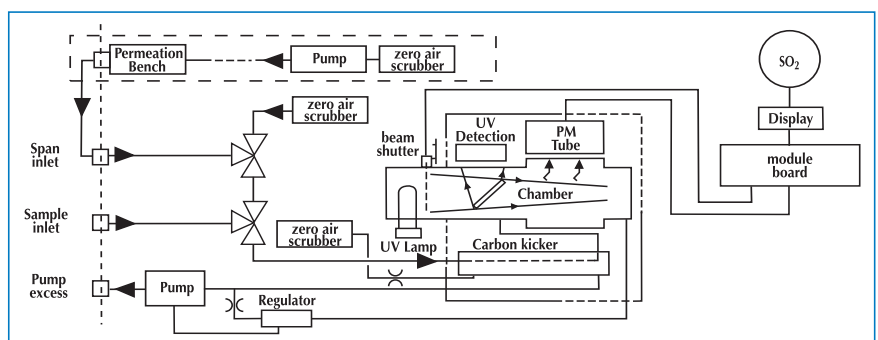

Distributed by:

